

INSTALLATION NOTES:

- ONE (1) INSTALLATION ANCHOR IS REQUIRED AT EACH ANCHOR LOCATION SHOWN.
- THE NUMBER OF INSTALLATION ANCHORS DEPICTED IS THE MINIMUM NUMBER OF ANCHORS TO BE USED FOR PRODUCT INSTALLATION. ANCHORS ARE TO MATCH TYPE, SIZE, AND EMBEDMENT OF THOSE SHOWN HEREIN FOR RESPECTIVE SUBSTRATE.
- SHIM AS REQUIRED AT EACH INSTALLATION ANCHOR WITH LOAD BEARING SHIM(S). MAXIMUM ALLOWABLE SHIM SIZE IS ¼ INCH. SHIM WHERE SPACE OF ¼ INCH OR GREATER OCCURS. SHIM(S) SHALL BE CONSTRUCTED OF HIGH DENSITY PLASTIC OR BETTER.
- FOR INSTALLATION INTO WOOD FRAMING, USE #10 WOOD SCREWS OF SUFFICIENT LENGTH TO ACHIEVE 1½ INCH MINIMUM EMBEDMENT.
- FOR INSTALLATION THROUGH 1X BUCK TO CONCRETE/ MASONRY, OR DIRECTLY INTO CONCRETE/ MASONRY, USE 3/16 INCH ITW TAPCONS OF SUFFICIENT LENGTH TO ACHIEVE 1¼ INCH MINIMUM EMBEDMENT.
- FOR INSTALLATION THROUGH METAL STUD USE #12-24 SELF-DRILLING SCREWS, GR. 5 OF SUFFICIENT LENGTH TO ACHIEVE 3 THREADS MINIMUM PENETRATION BEYOND METAL FRAME SUBSTRATE.
- MINIMUM EMBEDMENT AND EDGE DISTANCE EXCLUDE WALL FINISHES (INCLUDING BUT NOT LIMITED TO STUCCO, FOAM, BRICK VENEER, AND SIDING).
- INSTALLATION ANCHORS AND ASSOCIATED HARDWARE MUST BE MADE OF CORROSION RESISTANT MATERIAL OR HAVE A CORROSION RESISTANT COATING.
- FOR HOLLOW BLOCK AND GROUT FILLED BLOCK, DO NOT INSTALL INSTALLATION ANCHORS INTO MORTAR JOINTS. EDGE DISTANCE IS MEASURED FROM FREE EDGE OF BLOCK OR EDGE OF MORTAR JOINT INTO FACE SHELL OF BLOCK.
- INSTALLATION ANCHORS SHALL BE INSTALLED IN ACCORDANCE WITH ANCHOR MANUFACTURER'S INSTALLATION INSTRUCTIONS, AND ANCHORS SHALL NOT BE USED IN SUBSTRATES WITH STRENGTHS LESS THAN THE MINIMUM STRENGTH SPECIFIED BY THE ANCHOR MANUFACTURER BELOW.
- INSTALLATION ANCHOR CAPACITIES FOR PRODUCTS HEREIN ARE BASED ON SUBSTRATE MATERIALS WITH THE FOLLOWING PROPERTIES:
  - WOOD - MINIMUM SPECIFIC GRAVITY OF 0.55.
  - CONCRETE - MINIMUM COMPRESSIVE STRENGTH OF 3000 PSI.
  - MASONRY - UNIT STRENGTH CONFORMS TO ASTM C-90 WITH MINIMUM COMPRESSIVE STRENGTH OF 2000 PSI AND GROUT CONFORMS TO ASTM C476, MINIMUM GROUT COMPRESSIVE STRENGTH OF 2000PSI.
  - STEEL - MINIMUM YIELD STRENGTH OF 33 KSI. MINIMUM 18 GA. WALL THICKNESS.
  - ALUMINUM - MINIMUM 1/8 INCH THICK, 6063-T5 ALUMINUM

# ARCADIA, INC.

## SERIES C3550 SINGLE HUNG WINDOW (WZ3)(IMPACT)

GENERAL NOTES:

- THE PRODUCT SHOWN HEREIN IS DESIGNED AND MANUFACTURED TO COMPLY WITH THE CURRENT EDITION OF THE FLORIDA BUILDING CODE (FBC), EXCLUDING HVHZ AND HAS BEEN EVALUATED ACCORDING TO THE FOLLOWING:
  - AAMA/WDMA/CSA 101/I.S.2/A440-11/17
  - AAMA 506-16
  - ASTM E 1886-12/13A
  - ASTM E 1996-12A/14A/17
- ADEQUACY OF THE EXISTING STRUCTURAL CONCRETE/MASONRY AND 2X FRAMING AS A MAIN WIND FORCE RESISTING SYSTEM CAPABLE OF WITHSTANDING AND TRANSFERRING APPLIED PRODUCT LOADS TO THE FOUNDATION IS THE RESPONSIBILITY OF THE ENGINEER OR ARCHITECT OF RECORD FOR THE PROJECT OF INSTALLATION.
- 1X AND 2X BUCKS (WHEN USED) SHALL BE DESIGNED AND ANCHORED TO PROPERLY TRANSFER ALL LOADS TO THE STRUCTURE. BUCK DESIGN AND INSTALLATION IS THE RESPONSIBILITY OF THE ENGINEER OR ARCHITECT OF RECORD FOR THE PROJECT OF INSTALLATION.
- THE INSTALLATION DETAILS DESCRIBED HEREIN ARE GENERIC AND MAY NOT REFLECT ACTUAL CONDITIONS FOR A SPECIFIC SITE. IF SITE CONDITIONS CAUSE INSTALLATION TO DEVIATE FROM THE REQUIREMENTS DETAILED HEREIN, A LICENSED ENGINEER OR ARCHITECT SHALL PREPARE SITE SPECIFIC DOCUMENTS FOR USE WITH THIS DOCUMENT.
- APPROVED IMPACT PROTECTIVE SYSTEM **IS NOT REQUIRED** TO PROTECT THIS PRODUCT IN WIND ZONE 3 OR LESS.
- APPROVED IMPACT PROTECTIVE SYSTEM **IS REQUIRED** TO PROTECT THIS PRODUCT IN WIND ZONE 4.
- WINDOW FRAME MATERIAL: 6063-T5 ALUMINUM
- GLASS MEETS THE REQUIREMENTS OF ASTM E 1300 GLASS CHARTS. SEE SHEET 4 FOR GLAZING DETAIL.
- DESIGNATIONS "X" AND "O" STAND FOR THE FOLLOWING:
  - X: OPERABLE PANEL
  - O: FIXED PANEL

TABLE OF CONTENTS	
SHEET	DESCRIPTION
1	GENERAL NOTES
2	ELEVATION, ANCHOR LAYOUT, & DESIGN PRESSURE TABLE
3	VERTICAL SECTIONS
4	HORIZONTAL SECTIONS AND GLAZING DETAILS
5	COMPONENTS
6	BILL OF MATERIALS

DESIGN PRESSURE (PSF)	RATING
SEE SHEET 2	LARGE & SMALL MISSILE IMPACT (50 FPS)



ARCADIA, INC.  
2301 EAST VERNON AVE.  
VERNON, CA 90058  
PH: (323)771-9819

TITLE: C3550 SINGLE HUNG WINDOW  
(WZ3)(IMPACT)  
GENERAL NOTES

PREPARED BY:  
**BUILDING DROPS, INC.**  
398 E. DANIA BEACH BLVD., STE. 338  
DANIA BEACH, FL 33004  
PH: (954)399-8478  
FAX: (954)744-4738  
WEB: www.buildingdrops.com



REMARKS	BY	DATE

THE INSTALLATION DETAILS DESCRIBED HEREIN ARE GENERIC AND MAY NOT REFLECT ACTUAL CONDITIONS FOR A SPECIFIC SITE. IF SITE CONDITIONS CAUSE INSTALLATION TO DEVIATE FROM THE REQUIREMENTS DETAILED HEREIN, A LICENSED ENGINEER OR ARCHITECT SHALL PREPARE SITE SPECIFIC DOCUMENTS FOR USE WITH THIS DOCUMENT.

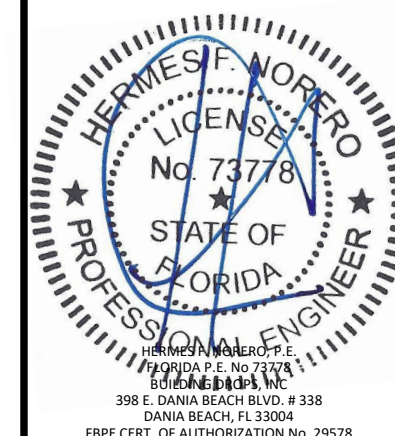

FL41642

DATE: 07.25.22

DWG. BY: CPA  
CHK. BY: HFN

SCALE: NTS

DWG. #: ARC009

SHEET:

1

OF 6

8/13/2022 7:57 PM

s:\projects\arcadia, inc\lbc-22-0648.2 - fbc submittal - c3550 single hung window\dwg\wz3\arc009.dwg

8/13/2022 7:58 PM  
s:\projects\arcadia, inc\lbc-22-0648-2 - lbc submittal - c3550 single hung window\dwg\wz3\arc009.dwg

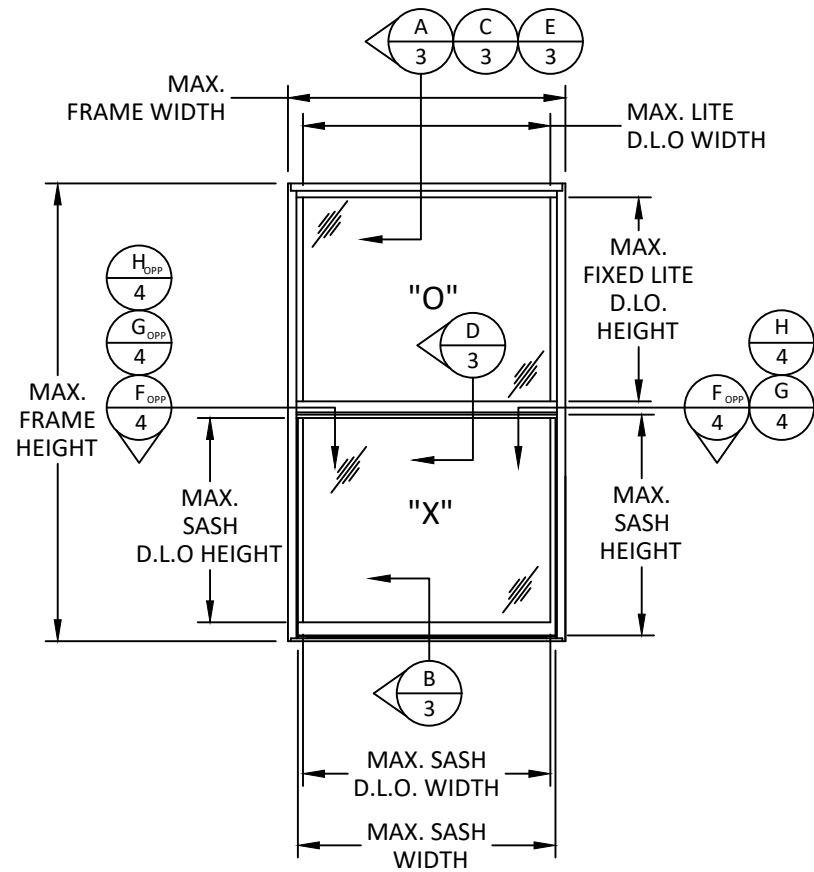

**ELEVATION**

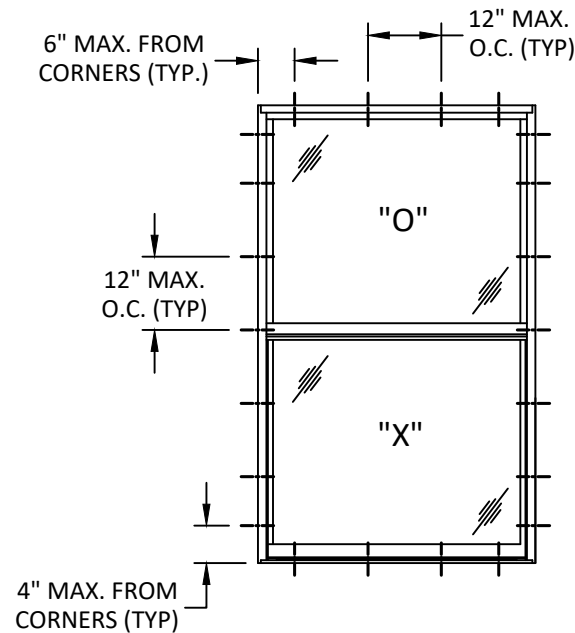

**ANCHOR LAYOUT  
THRU FRAME**

TABLE 1: ANCHOR SCHEDULE

ANCHOR	SUBSTRATE	MIN. EMBEDMENT	MIN. EDGE DISTANCE
3/16" ITW TAPCON	CONCRETE (MIN 3000 PSI)	1-1/4"	2-1/2"
	MASONRY (ASTM C-90)		
#10 WOOD SCREW	2X WOOD BUCK (MIN. S.G. = 0.55)	1-1/2"	3/4"
#12-24 SELF-DRILLING SCREWS GR. 5	ALUMINUM (6063-T5)	3 THREADS MIN.	3/4"
	STEEL (MIN. YEILD 33KSI)		

- NOTE:
- 1.) SASH WIDTH = FRAME WIDTH - 3.5
  - 2.) SASH HEIGHT = (FRAME HEIGHT/2) + 0.4375
  - 3.) SASH D.L.O. WIDTH = FRAME WIDTH - 6.5
  - 4.) SASH D.L.O. HEIGHT = (FRAME HEIGHT/2) - 5.375
  - 5.) FIXED D.L.O. WIDTH = FRAME WIDTH - 6.375
  - 6.) FIXED D.L.O. HEIGHT = (FRAME HEIGHT/2) - 5.375

DESIGN PRESSURE (PSF)		
WINDOW DIMENSIONS		EXT (+)
WIDTH	HEIGHT	INT (-)
36	60	65
39		65
42		65
45		65
48		65
51	63	59
54		49
57		41
36		65
39		65
42	66	65
45		65
48		65
51		55
54		47
36	69	65
39		65
42		65
45		65
48		65
36	72	65
39		65
42		65
45		65
48		65
36	75	65
39		65
42		65
45		65
48		65
36	78	65
39		65
42		65
45		65
48		65
36	81	65
39		65
42		65
45		65
48		65
36	84	65
39		65
42		65
45		65
48		65
36	87	65
39		65
42		65
45		65
48		65
36	90	65
39		65
42		65
45		65
48		65
36	96	65
39		65
42		65
45		65
48		65



ARCADIA, INC.  
2301 EAST VERNON AVE.  
VERNON, CA 90058  
PH: (323)771-9819

TITLE: C3550 SINGLE HUNG WINDOW  
(WZ3)(IMPACT)  
ELEVATION, ANCHOR LAYOUT,  
& DESIGN PRESSURE TABLE

PREPARED BY:  
**BUILDING DROPS, INC.**  
398 E. DANIA BEACH BLVD., STE. 338  
DANIA BEACH, FL 33004  
PH: (954)399-8478  
FAX: (954)744-4738  
WEB: www.buildingdrops.com



REMARKS	BY	DATE

THE INSTALLATION DETAILS DESCRIBED HEREIN ARE GENERIC AND MAY NOT REFLECT ACTUAL CONDITIONS FOR A SPECIFIC SITE. IF SITE CONDITIONS CAUSE INSTALLATION TO DEVIATE FROM THE REQUIREMENTS DETAILED HEREIN, A LICENSED ENGINEER OR ARCHITECT SHALL PREPARE SITE SPECIFIC DOCUMENTS FOR USE WITH THIS DOCUMENT.

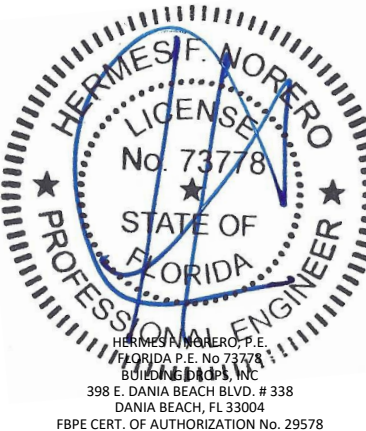

**FL41642**

DATE: **07.25.22**

DWG. BY: **CPA** | CHK. BY: **HFN**

SCALE: **NTS**

DWG. #: **ARC009**

SHEET:

**2**

OF 6

8/13/2022 7:58 PM  
s:\projects\arcadia, inc\lbc-22-0648-2 - fbc submittal - c3550 single hung window\dwg\w3\arc009.dwg

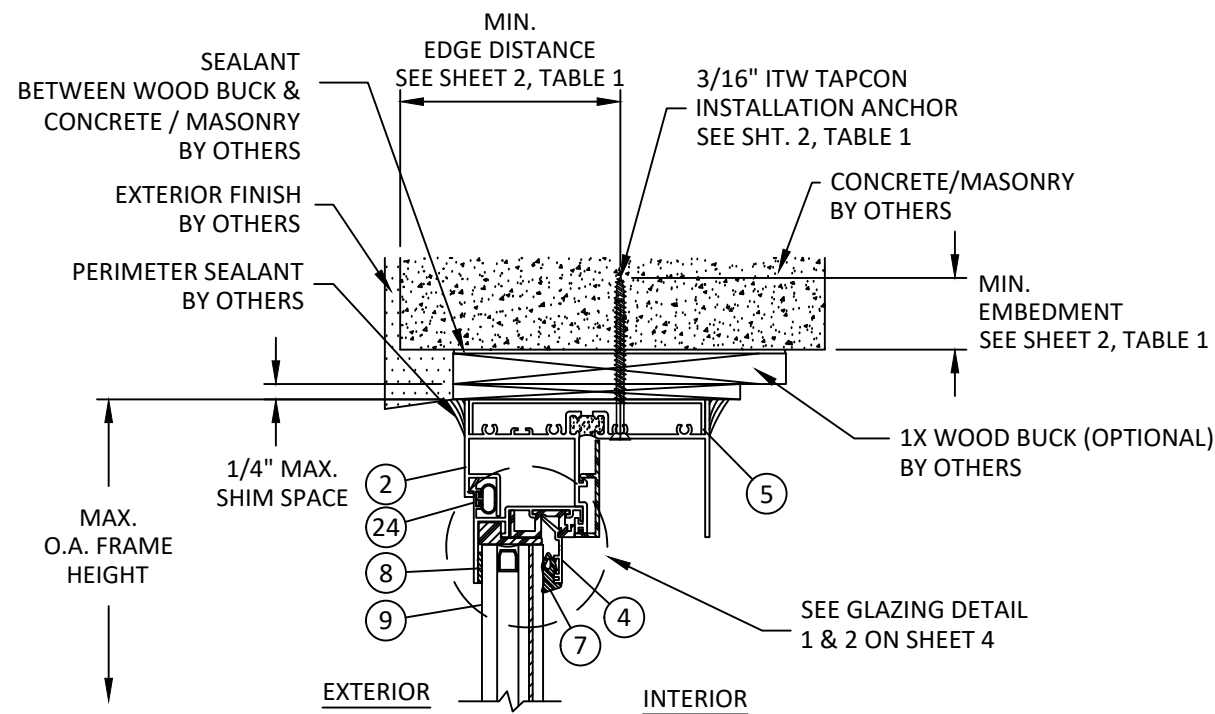

**A**  
**3** VERTICAL SECTION  
CONCRETE/MASONRY  
SHEAR PLATE INSTALLATION

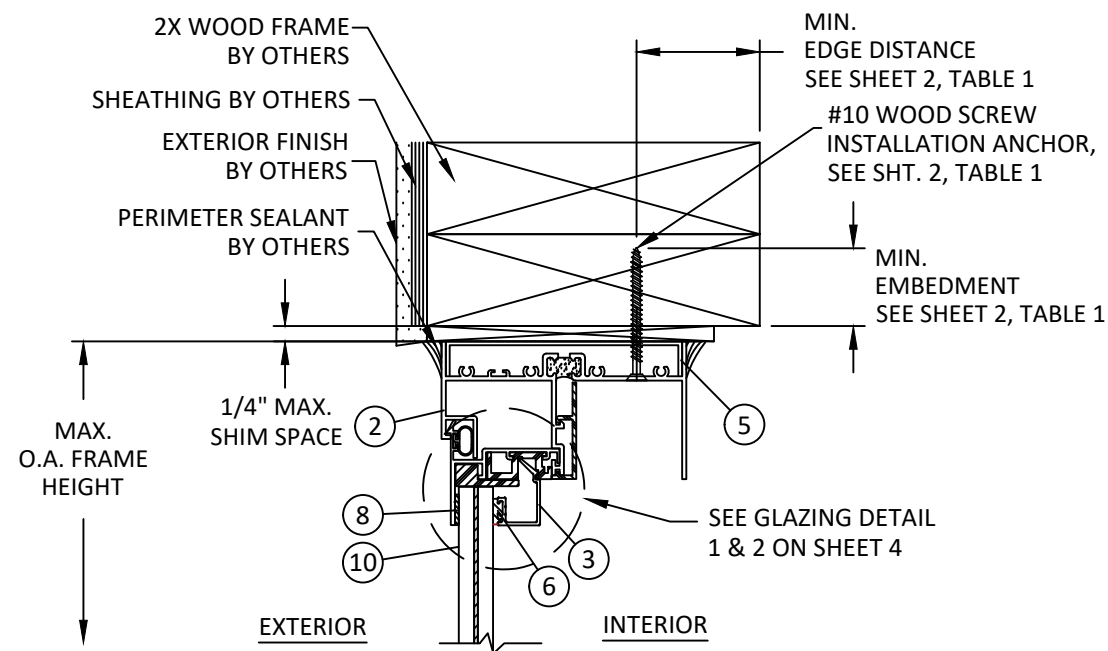

**C**  
**3** VERTICAL SECTION  
2X WOOD FRAMING  
SHEAR PLATE INSTALLATION

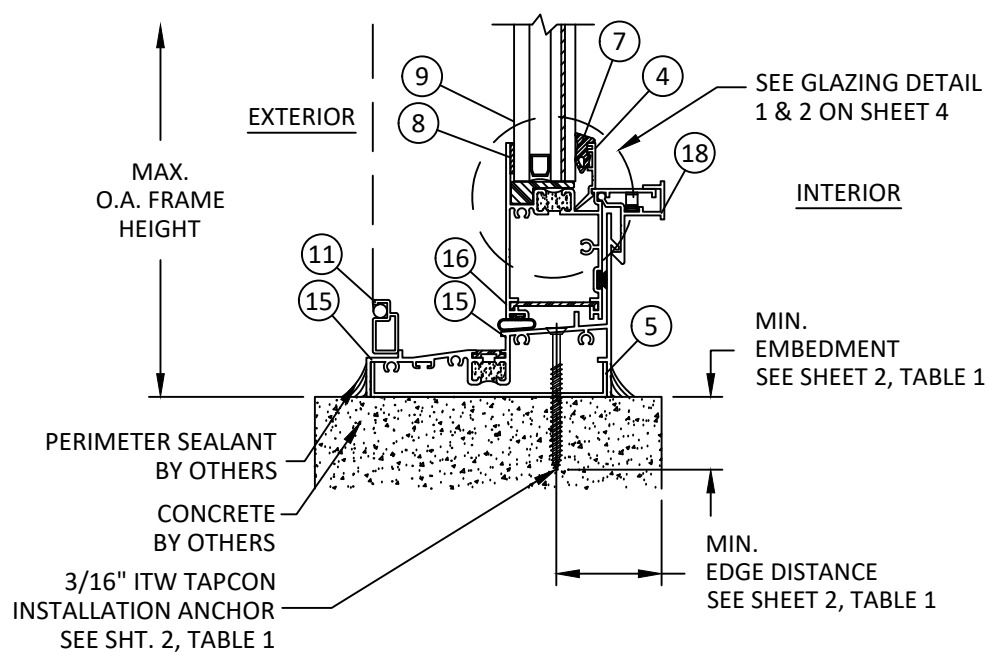

**B**  
**3** VERTICAL SECTION  
CONCRETE/MASONRY  
SHEAR PLATE INSTALLATION

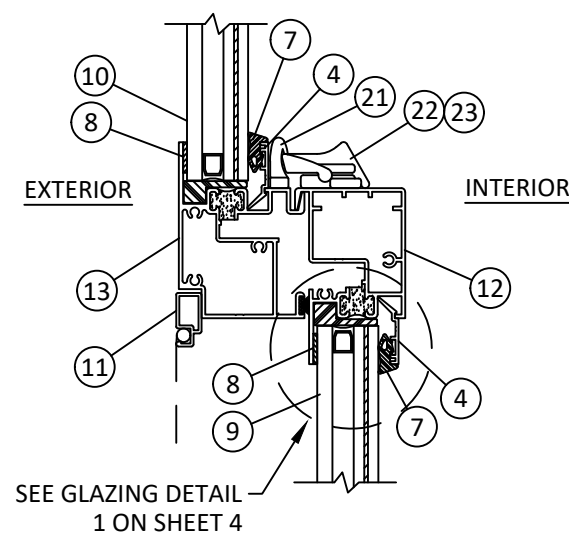

**D**  
**3** VERTICAL SECTION  
MEETING RAIL

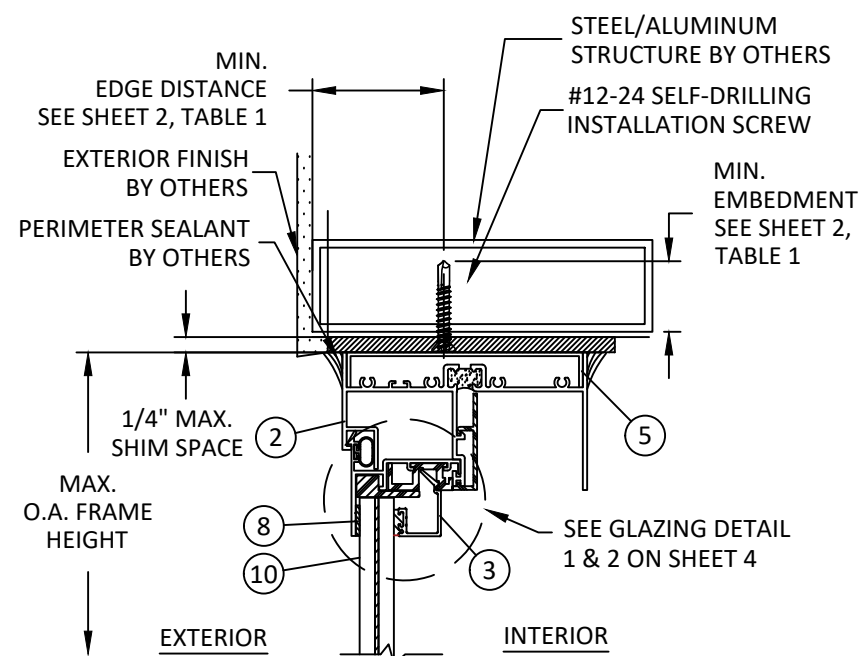

**E**  
**3** VERTICAL SECTION  
ALUMINUM/STEEL  
SHEAR PLATE INSTALLATION



ARCADIA, INC.  
2301 EAST VERNON AVE.  
VERNON, CA 90058  
PH: (323)771-9819

TITLE: C3550 SINGLE HUNG WINDOW  
(W23)(IMPACT)  
VERTICAL SECTIONS

PREPARED BY:  
**BUILDING DROPS, INC.**  
398 E. DANIA BEACH BLVD., STE. 338  
DANIA BEACH, FL 33004  
PH: (954)399-8478  
FAX: (954)474-4738  
WEB: www.buildingdrops.com



REMARKS	BY	DATE

THE INSTALLATION DETAILS DESCRIBED HEREIN ARE GENERIC AND MAY NOT REFLECT ACTUAL CONDITIONS FOR A SPECIFIC SITE. IF SITE CONDITIONS CAUSE INSTALLATION TO DEVIATE FROM THE REQUIREMENTS DETAILED HEREIN, A LICENSED ENGINEER OR ARCHITECT SHALL PREPARE SITE SPECIFIC DOCUMENTS FOR USE WITH THIS DOCUMENT.

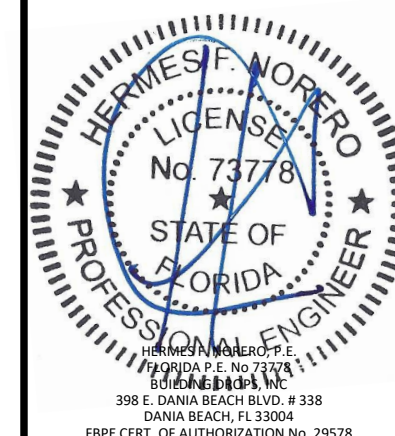

**FL41642**

DATE: **07.25.22**

DWG. BY:  
**CPA**

CHK. BY:  
**HFN**

SCALE: **NTS**

DWG. #: **ARC009**

SHEET:

**3**

OF 6



8/13/2022 7:58 PM  
s:\projects\arcadia, inc\lbc-22-0648-2 - fbc submittal - c3550 single hung window\dwg\wz3\arc009.dwg

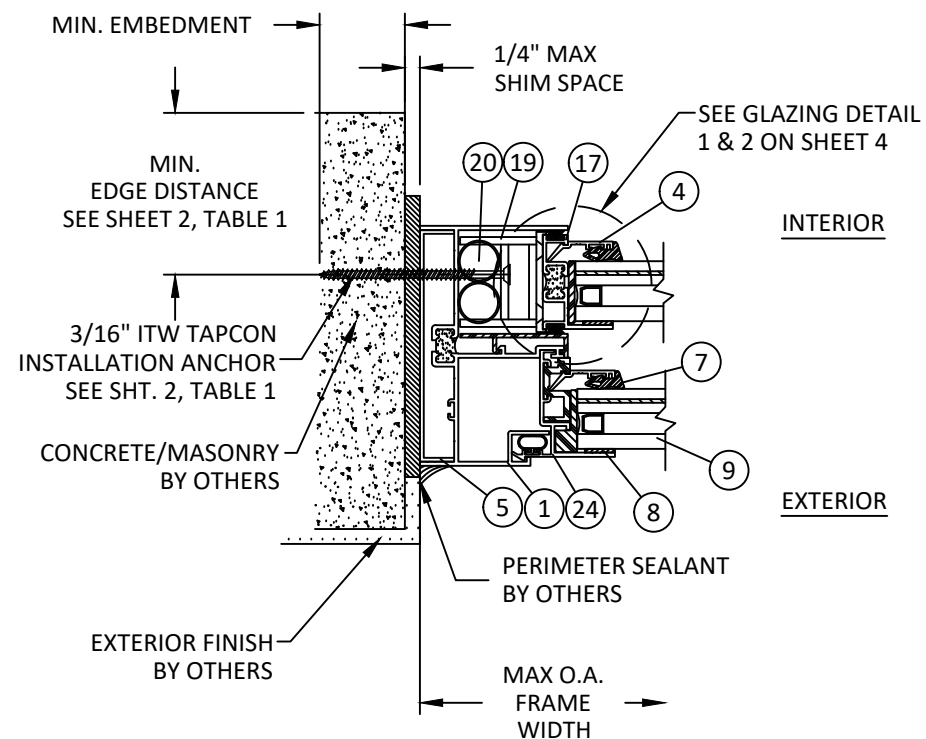

**F**  
**4** HORIZONTAL SECTION  
CONCRETE/MASONRY  
SHEAR PLATE INSTALLATION

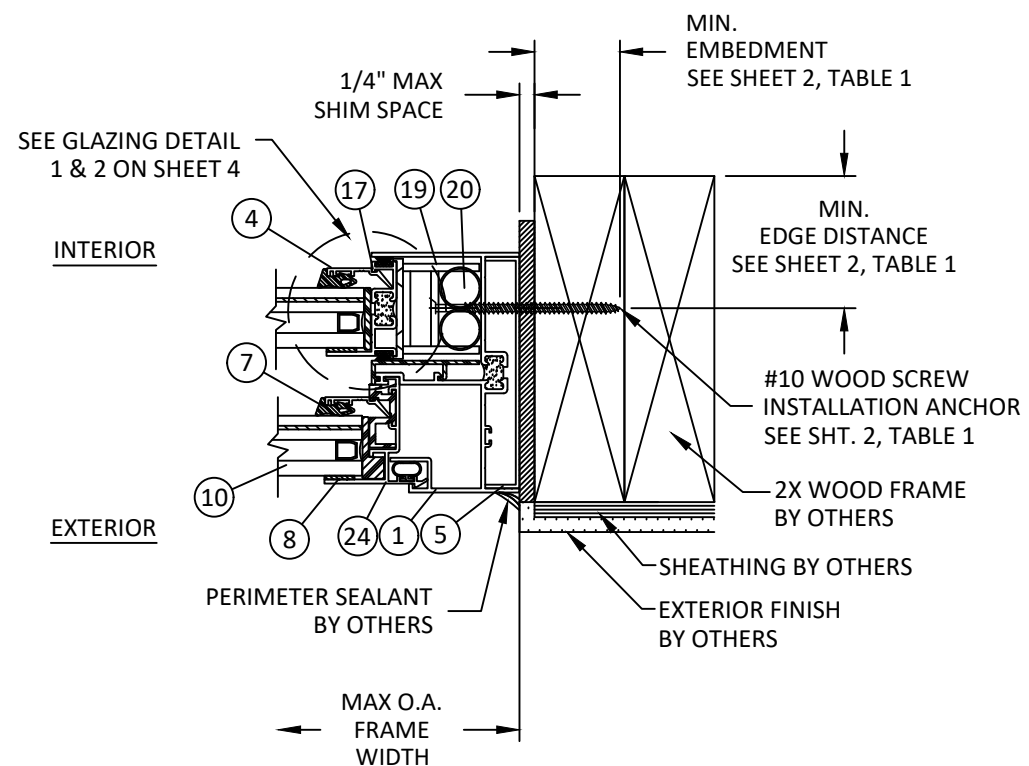

**G**  
**4** HORIZONTAL SECTION  
2X WOOD BUCK  
SHEAR PLATE INSTALLATION

9/16" O.A. LAMINATED GLASS CONSISTING OF:  
1/4" ANNEALED GLASS,  
0.090 SAFLEX PVB BY EASTMAN,  
1/4" ANNEALED GLASS

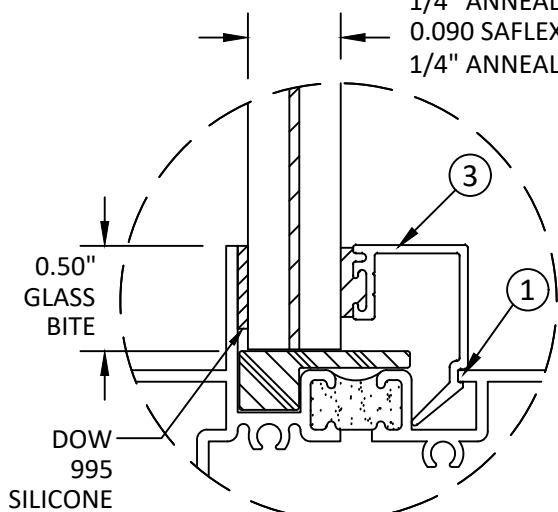

GLAZING DETAIL 1

1 1/16" INSULATED GLASS CONSISTING OF:  
1/4" ANNEALED GLASS,  
1/2" ALUMINUM SPACER & AIR SPACE,  
1/4" ANNEALED GLASS  
0.090 SAFLEX PVB BY EASTMAN,  
1/4" ANNEALED GLASS

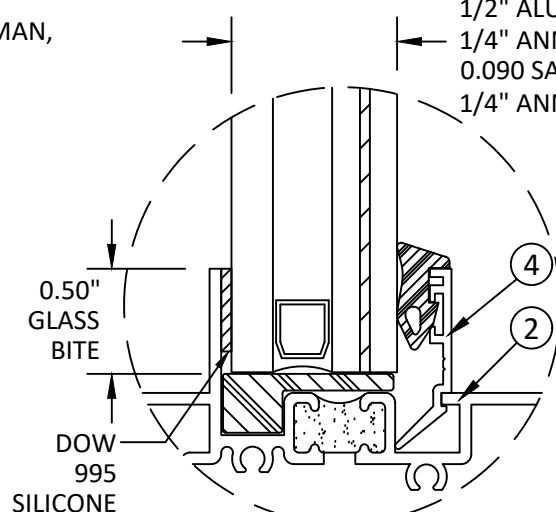

GLAZING DETAIL 2

GLAZING NOTES:

- GLASS TYPE AND THICKNESS SHALL COMPLY WITH ASTM E1300 REQUIREMENTS AS WELL AS APPLICABLE SAFETY GLAZING REQUIREMENTS PER THE FBC. THICKNESS, TEMPER, AND SAFETY GLAZING REQUIREMENTS SHALL BE REVIEWED ON A SITE SPECIFIC BASIS.
- SETTING BLOCK DUROMETER HARDNESS OF 70-90 (SHORE A) AS REFERENCED IN FBC CHAPTER 24.
- SETTING BLOCKS TO BE LOCATED AT 1/4 SPAN LENGTH FOR GLASS WIDER THAN 36" AS PER FBC CHAPTER 24.
- D.L.O. AND DESIGN PRESSURES MAY NOT EXCEED MAX VALUES ON SHEET 2.

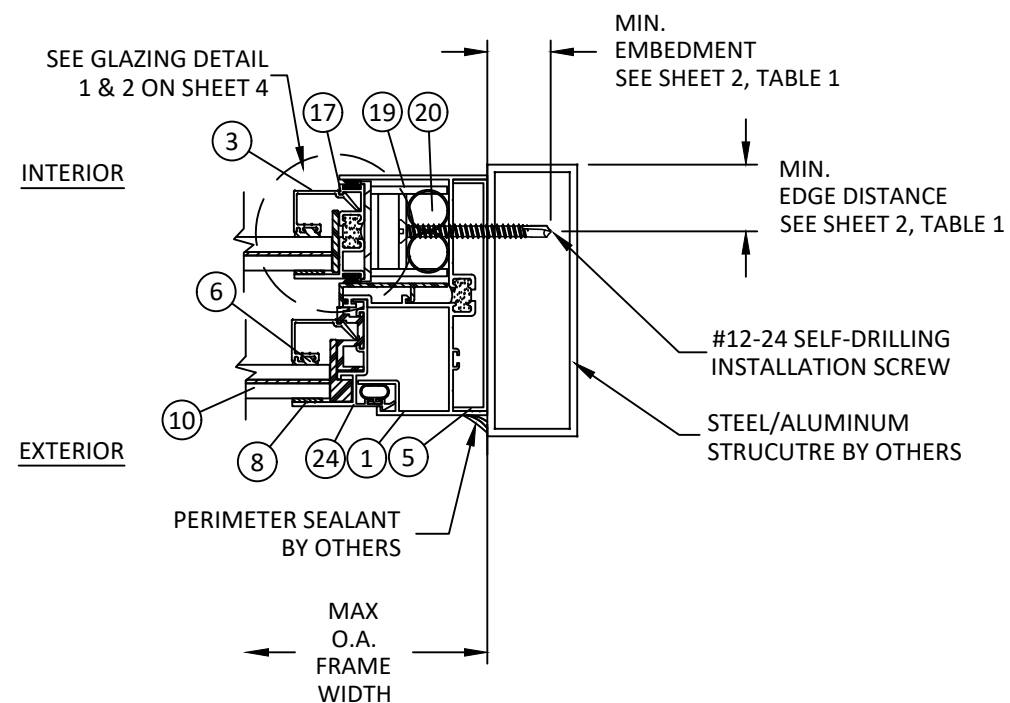

**H**  
**4** HORIZONTAL SECTION  
ALUMINUM/STEEL  
SHEAR PLATE INSTALLATION



ARCADIA, INC.  
2301 EAST VERNON AVE.  
VERNON, CA 90058  
PH: (323)771-9819

TITLE: C3550 SINGLE HUNG WINDOW  
(WZ3)(IMPACT)

HORIZONTAL SECTIONS  
& GLAZING DETAILS

PREPARED BY:

**BUILDING DROPS, INC.**  
398 E. DANIA BEACH BLVD., STE. 338  
DANIA BEACH, FL 33004  
PH: (954)399-8478  
FAX: (954)744-4738  
WEB: www.buildingdrops.com



REMARKS	BY	DATE

THE INSTALLATION DETAILS DESCRIBED HEREIN ARE GENERIC AND MAY NOT REFLECT ACTUAL CONDITIONS FOR A SPECIFIC SITE. IF SITE CONDITIONS CAUSE INSTALLATION TO DEVIATE FROM THE REQUIREMENTS DETAILED HEREIN, A LICENSED ENGINEER OR ARCHITECT SHALL PREPARE SITE SPECIFIC DOCUMENTS FOR USE WITH THIS DOCUMENT.

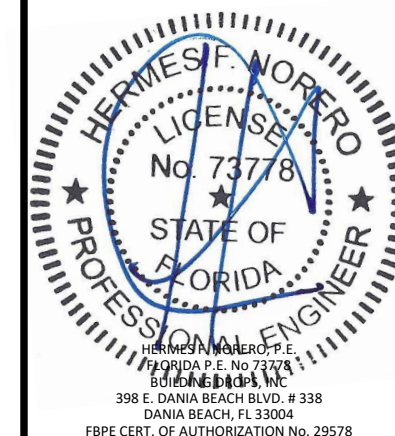

**FL41642**

DATE: **07.25.22**

DWG. BY:  
**CPA**

CHK. BY:  
**HFN**

SCALE: **NTS**

DWG. #: **ARC009**

SHEET:

**4**

OF 6

8/13/2022 7:58 PM  
s:\projects\arcadia, inc\fbrc-22-0648.2 - fbrc submittal - c3550 single hung window\dwg\wz3\arc009.dwg



ARCADIA, INC.  
2301 EAST VERNON AVE.  
VERNON, CA 90058  
PH: (323)771-9819

TITLE: C3550 SINGLE HUNG WINDOW  
(WZ3)(IMPACT)  
COMPONENTS

PREPARED BY:  
**BUILDING DROPS, INC.**  
398 E. DANIA BEACH BLVD., STE. 338  
DANIA BEACH, FL 33004  
PH: (954)399-8478  
FAX: (954)744-4738  
WEB: www.buildingdrops.com



REMARKS	BY	DATE

THE INSTALLATION DETAILS DESCRIBED HEREIN ARE GENERIC AND MAY NOT REFLECT ACTUAL CONDITIONS FOR A SPECIFIC SITE. IF SITE CONDITIONS CAUSE INSTALLATION TO DEVIATE FROM THE REQUIREMENTS DETAILED HEREIN, A LICENSED ENGINEER OR ARCHITECT SHALL PREPARE SITE SPECIFIC DOCUMENTS FOR USE WITH THIS DOCUMENT.

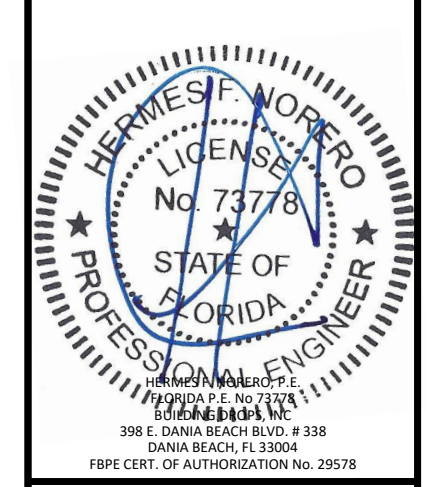

**FL41642**

DATE: **07.25.22**

DWG. BY: **CPA**      CHK. BY: **HFN**

SCALE: **NTS**

DWG. #: **ARC009**

SHEET:  
**5**  
OF 6

**1** FRAME RIGHT/LEFT JAMB  
6063-T5

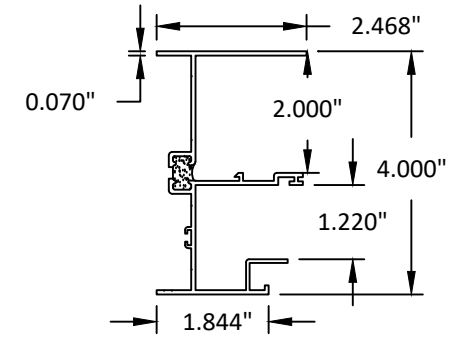

**2** FRAME HEAD  
6063-T5

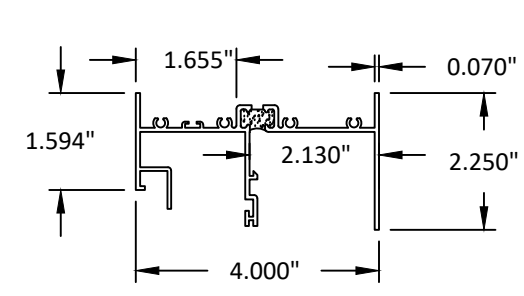

**3** 3/8" GLAZING BEAD  
6063-T5

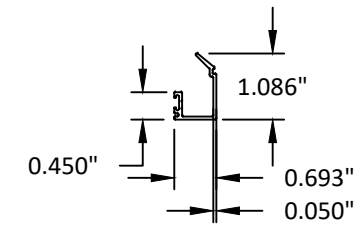

**4** 1" GLAZING BEAD  
6063-T5

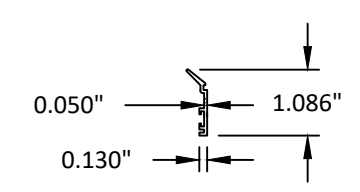

**11** SCREEN  
6063-T5

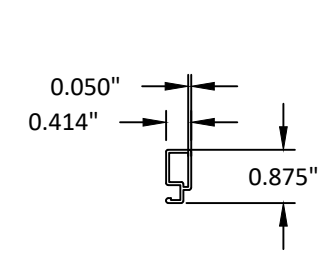

**12** TOP RAIL  
6063-T5

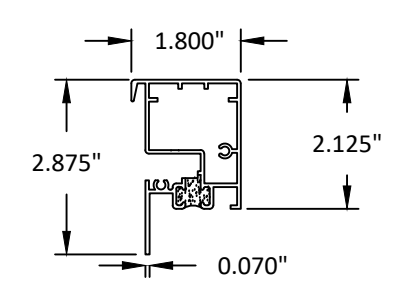

**13** MEETING RAIL  
6063-T5

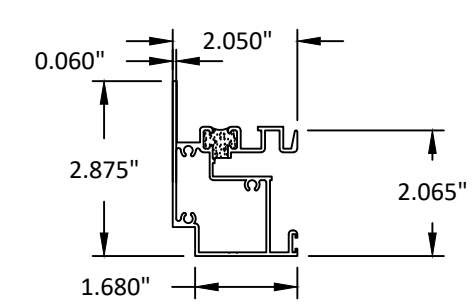

**15** FRAME SILL  
6063-T5

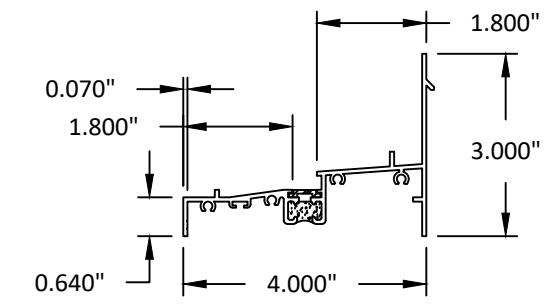

**16** BOTTOM RAIL  
6063-T5

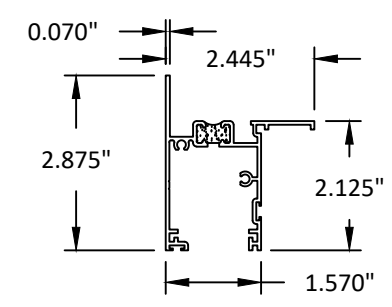

**17** SIDE RAIL  
6063-T5

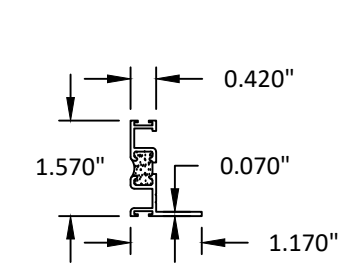

**18** LATCH  
6063-T5

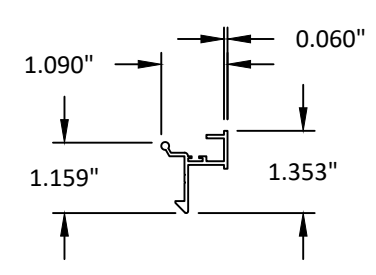

**19** SPIRAL BALANCER BRACKET  
STAINLESS STEEL

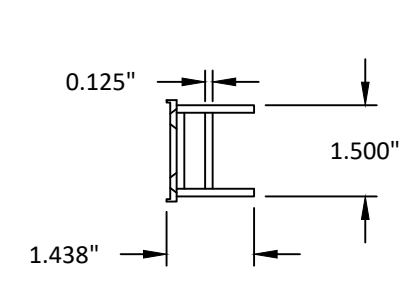

**24** FRAME INSTERT HEAD/JAMB  
6063-T5

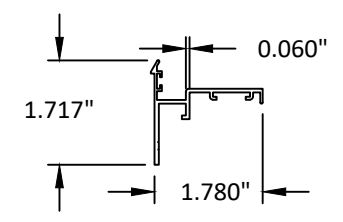

8/13/2022 7:58 PM  
s:\projects\arcadia, inc\fbrc-22-0648.2 - fbc submittal - c3550 single hung window\dwgs\wz3\arc009.dwg

BILL OF MATERIAL				
ITEM NO.	PART NO.	DESCRIPTION	MATERIAL	VENDOR
1	E3553	FRAME - RIGHT/LEFT JAMB	ALUMINUM EXTRUSION	EXTRUDERS
2	E3551	FRAME - HEAD	ALUMINUM EXTRUSION	EXTRUDERS
3	E3572	3/8" GLAZING BEAD	ALUMINUM EXTRUSION	EXTRUDERS
4	E3558	1" GLAZING BEAD	ALUMINUM EXTRUSION	EXTRUDERS
5	-	SHEAR PLATE	ALUMINUM EXTRUSION	EXTRUDERS
6	WH308	1/16" X 1/8" SPACER TAPE	FOAM	TB PHILLY
7	P9982	GLAZING WEDGE	EPDM	EPG
8	SSD995	SILICONE SEALANT	SILICONE	TB PHILLY
9	GLASS: 1-1/16" INS. (1/4" ANN) / (1/2" AS) / (1/8" ANN), .090 PVB, (1/8" ANN)			VARIOUS SOURCES
10	GLASS: 9/16" O.A. LAMI. (1/4" ANN) / 0.090 PVB, (1/4" ANN)			VARIOUS SOURCES
11	-	SCREEN	ALUMINUM EXTRUSION	EXTRUDERS
12	E3508	TOP RAIL	ALUMINUM EXTRUSION	EXTRUDERS
13	E3555	MEETING RAIL	ALUMINUM EXTRUSION	EXTRUDERS
14	-	WINDOW LOCK	ALUMINUM EXTRUSION	EXTRUDERS
15	E3552	FRAME SILL	ALUMINUM EXTRUSION	EXTRUDERS
16	E3509	BOTTOM RAIL	ALUMINUM EXTRUSION	EXTRUDERS
17	E3507	SIDE RAIL	ALUMINUM EXTRUSION	EXTRUDERS
18	E3510	LATCH	ALUMINUM EXTRUSION	EXTRUDERS
19	S3556	SPIRAL BALANCER BRACKET	STAINLESS STEEL	
20		SPIRAL BALANCER		
21	DH356	KEEPER	WHITE BRONZE	
22	DH357	LH SWEEP LATCH	WHITE BRONZE	
23	DH358	LH SWEEP LATCH	WHITE BRONZE	
24	E3554	FRAME INSERT HEAD/JAMB	ALUMINUM EXTRUSION	EXTRUDERS
25	V3531	HEAD/JAMB INSERT BARRIER	RIGID PVC	



ARCADIA, INC.  
2301 EAST VERNON AVE.  
VERNON, CA 90058  
PH: (323)771-9819

TITLE: C3550 SINGLE HUNG WINDOW (WZ3)(IMPACT)  
BILL OF MATERIALS

PREPARED BY:  
BUILDING DROPS, INC.  
398 E. DANIA BEACH BLVD., STE. 338  
DANIA BEACH, FL 33004  
PH: (954)399-8478  
FAX: (954)744-4738  
WEB: www.buildingdrops.com



REMARKS	BY	DATE

THE INSTALLATION DETAILS DESCRIBED HEREIN ARE GENERIC AND MAY NOT REFLECT ACTUAL CONDITIONS FOR A SPECIFIC SITE. IF SITE CONDITIONS CAUSE INSTALLATION TO DEVIATE FROM THE REQUIREMENTS DETAILED HEREIN, A LICENSED ENGINEER OR ARCHITECT SHALL PREPARE SITE SPECIFIC DOCUMENTS FOR USE WITH THIS DOCUMENT.

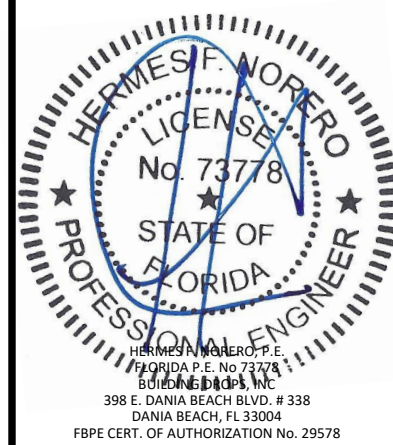

**FL41642**

DATE:	07.25.22	
DWG. BY:	CPA	CHK. BY: HFN
SCALE:	NTS	
DWG. #:	ARC009	

SHEET:  
**6**  
OF 6